

ECLATEC



Collection
CONVENTIONNELLE
2017

SOMMAIRE

					
NISMO	p.3	INDICE LYRE	p.4	ELYXE	p.5

					
ECLAT	p.6	PALEO	p.7	MURENA	p.8

					
CLIP	p.9	MOANA	p.10	ENZA	p.11

					
ELIPT	p.12	CHORUS	p.13	FORVIL	p.14

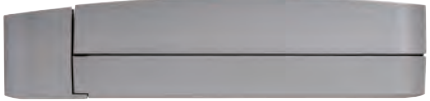
	
PIXEL	p.15

NISMO

Design luminaire : Michel TORTA

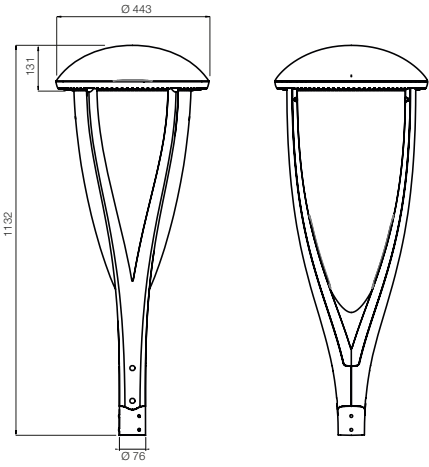

DISTRIBUTION PHOTOMÉTRIQUE

NISMO - Optique circulaire IMPGZ12 90W

📍 Positionnement du mât

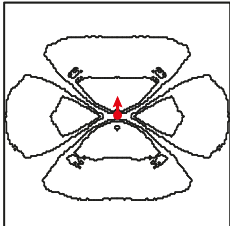

INDICE LYRE

Design luminaire : Eclatec

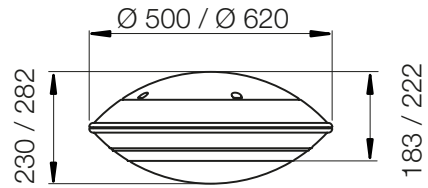

Indice Graphic

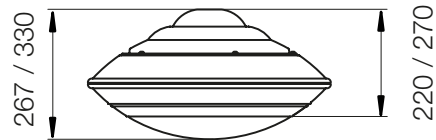

Indice Spiral

DISTRIBUTION PHOTOMÉTRIQUE

INDICE LYRE 500 OP27
70W

↑ Positionnement du mât

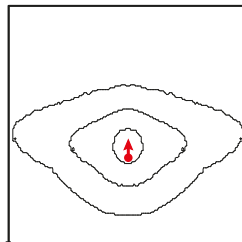

ELYXE

Design luminaire : L. DAVY

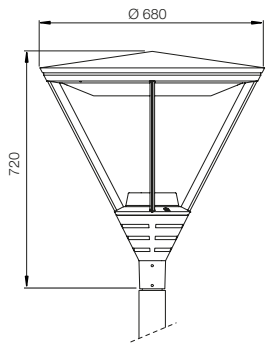

Elyxe porté

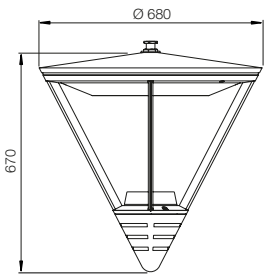

Elyxe suspendu

DISTRIBUTION PHOTOMÉTRIQUE

ELYXE LX-R -
IMPGZ12 90W

↑ Positionnement du mât

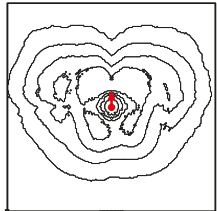

Elyxe Indigo



Elyxe Altaïs



Elyxe Indigo suspendu

ECLAT

Design luminaire : Eclatec

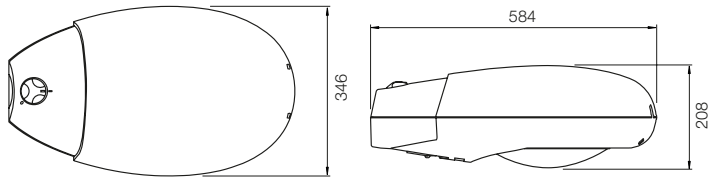

DISTRIBUTION PHOTOMÉTRIQUE

ECLAT OP27-100W

↑ Positionnement du mât

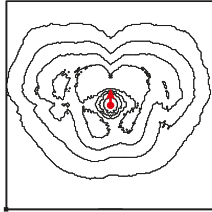

Eclat Berry



Eclat Baltic



Eclat Cytise

PALEO

Design luminaire : Eclatec

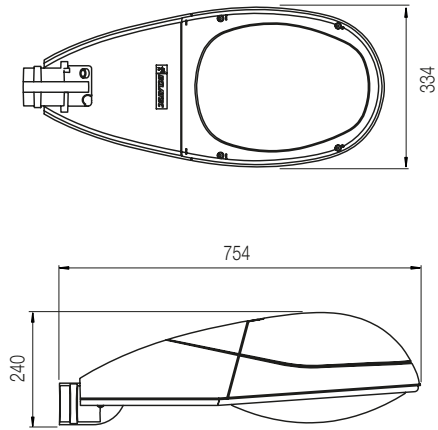

DISTRIBUTION PHOTOMÉTRIQUE

PALEO OP34-100W

↑ Positionnement du mât

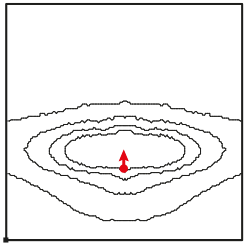

Paleo Etna



Paleo Musa



Paleo Paros

MURENA

Design luminaire : Eclatec

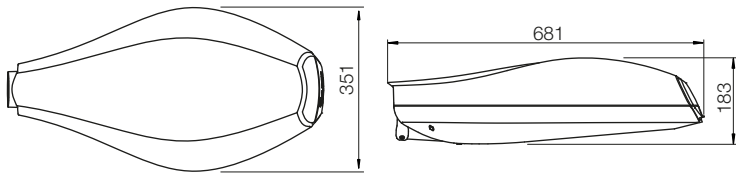

DISTRIBUTION PHOTOMÉTRIQUE

MURENA - ECLAPACK 31-100W

↑ Positionnement du mât

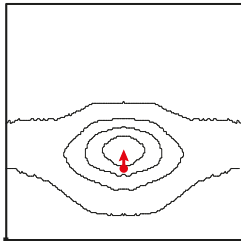

Murena Chanteraine



Murena Chrome



Murena Berry avec enjoliveur

CLIP

Design luminaire : Marc AUREL

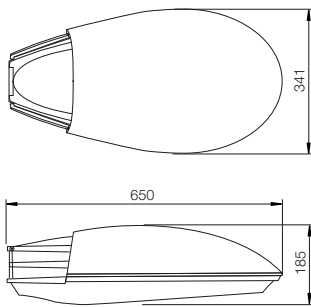

Clip 28

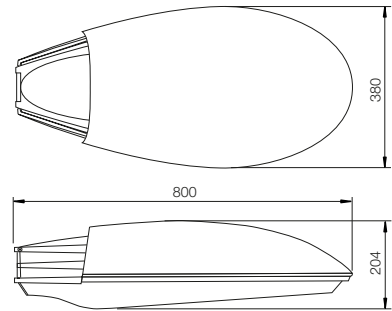

Clip 34

DISTRIBUTION PHOTOMETRIQUE

CLIP 28 - OP27-100W

↑ Positionnement du mât

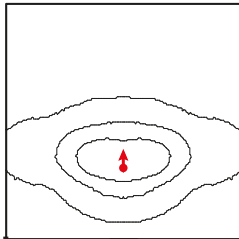

Clipart

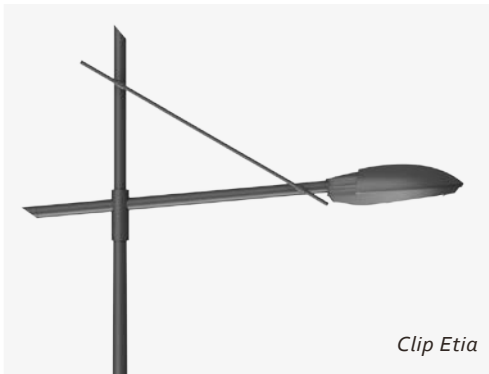

Clip Etia



Cliptown

MOANA

Design luminaire : Eclatec

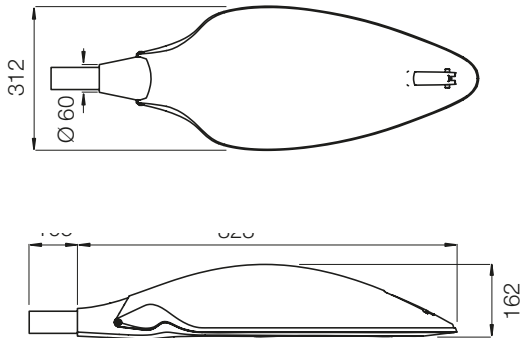

DISTRIBUTION PHOTOMÉTRIQUE

MOANA - OP19 -140W

▲ Positionnement du mât

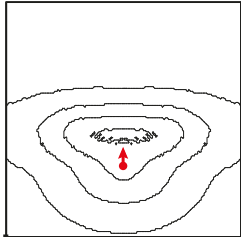

Moana Chantereine



Moana Charbonnière



Moana Palama

ENZA

Design luminaire : Marc AUREL

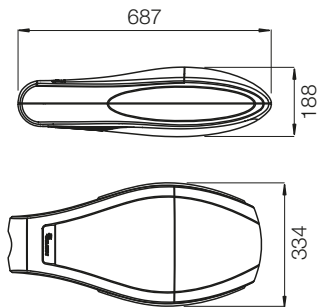

Enza 25

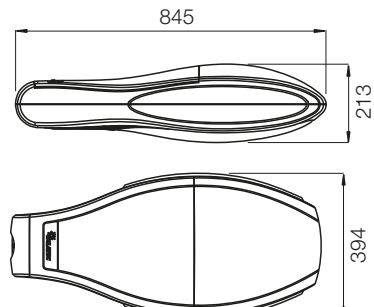

Enza 35

DISTRIBUTION PHOTOMETRIQUE

ENZA - OP25 -150W

▲ Positionnement du mât

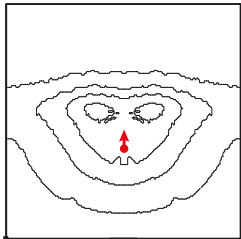

Enza Donna



Enza Karma



Enza Orkid - enjolvieur City

ELIPT

Design luminaire : Jean-Michel WILMOTTE

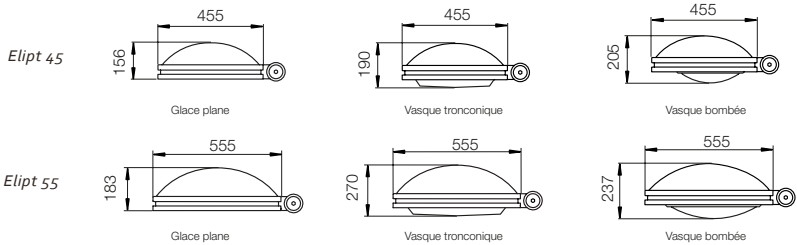

DISTRIBUTION PHOTOMETRIQUE

ELIPT - OP27 -100W

↑ Positionnement du mât

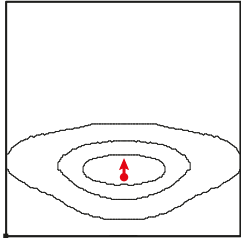

CHORUS

Design luminaire : Eclatec

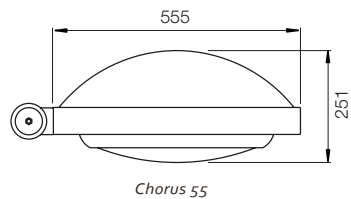
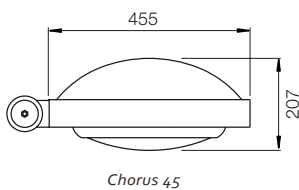

DISTRIBUTION PHOTOMÉTRIQUE

CHORUS - OP27 -100W

↑ Positionnement du mât

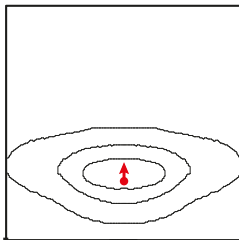

Chorus KC



Chorus Musa



Chorus Cytise

FORVIL

Design luminaire : Eclatec

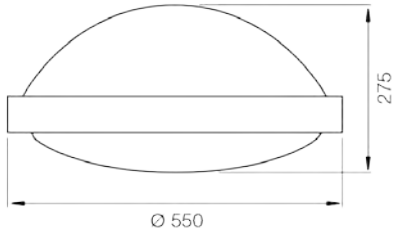
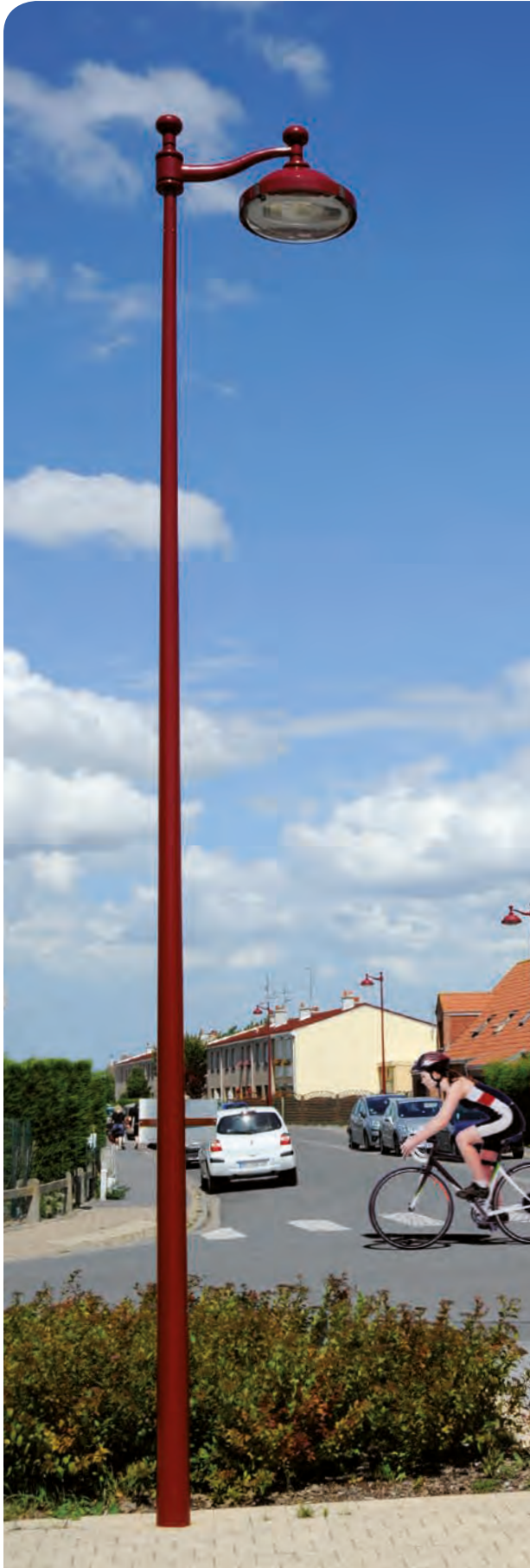

DISTRIBUTION PHOTOMÉTRIQUE

FORVIL - Multitec 73 -150W

↑ Positionnement du mât

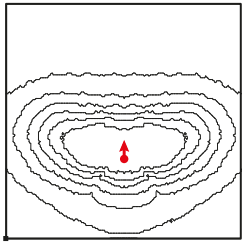

PIXEL

Design luminaire : STOA Architecture

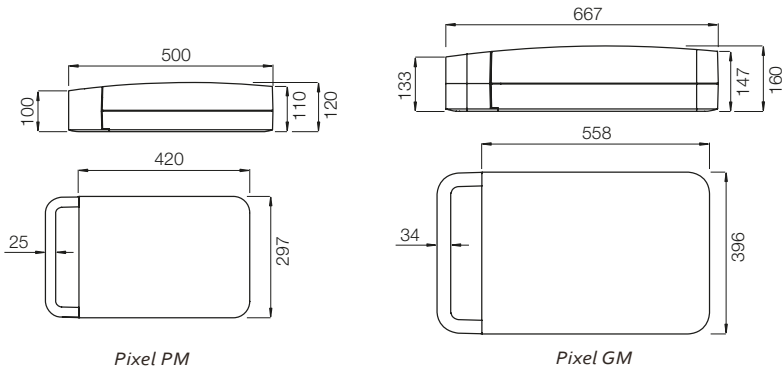
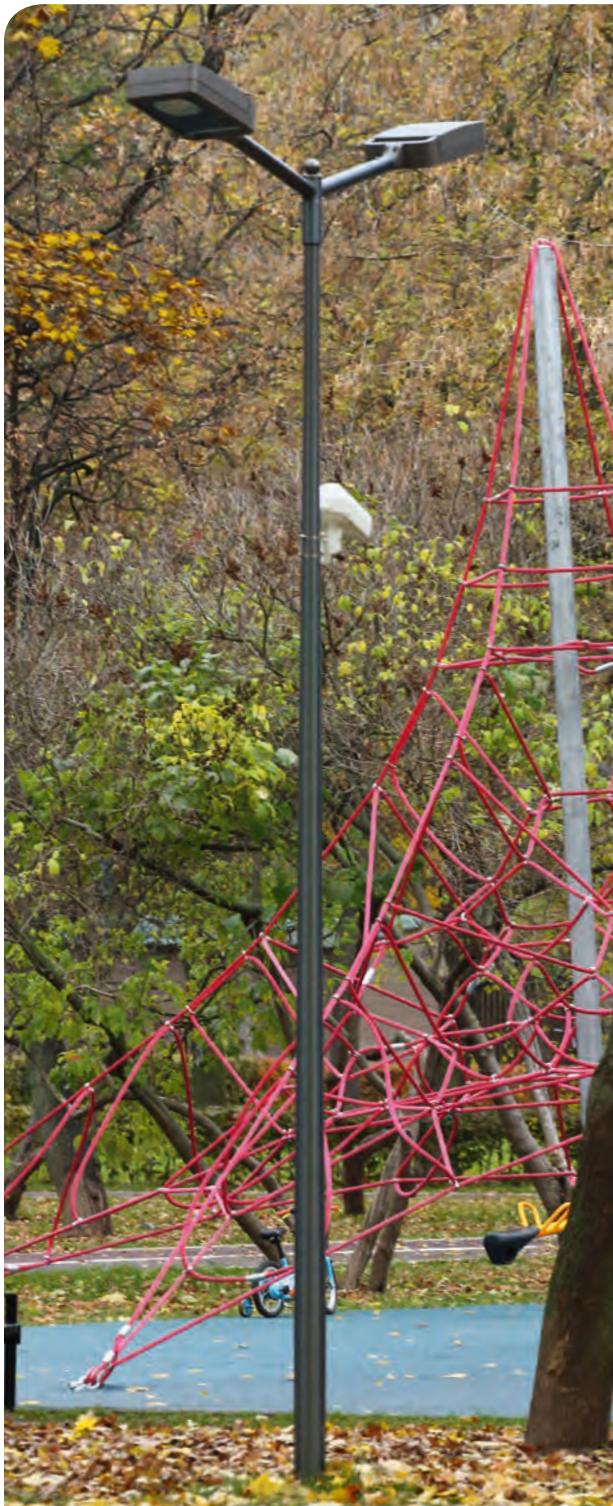

DISTRIBUTION PHOTOMÉTRIQUE

PIXEL - OP20 - 70W

▲ Positionnement du mât

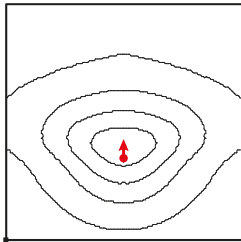

Agence Centre

6, rue des Artisans
ZA - BP 338
37303 Joue-Les-Tours
Tél : 02 47 41 61 94
Fax : 02 47 40 80 74
regioncentre@ghm-eclatec.fr

ECLATEC

Production et siège social

41, rue Lafayette
54320 Maxéville
Tél : 03 83 39 38 00
Fax : 03 83 37 16 16
www.eclatec.com

